



# CATOFIN® Dehydrogenation

## Overview

The CATOFIN® dehydrogenation process is a reliable, proven route for the production of isobutylene, n-butenes, or propylene from isobutane, n-butane, or propane respectively. CB&I has exclusive worldwide licensing rights to the technology. More than 30 plants have utilized this technology to produce products ranging from propylene to isobutylene, butadiene, butylenes and isoprene. CB&I has been awarded two units in Asia to co-process mixed feedstock. One unit will produce propylene and isobutylene as products while the other unit will produce isobutylene and normal butenes as products. At total of 14 C<sub>3</sub> CATOFIN units have been licensed for production of propylene.

The CATOFIN process uses fixed-bed reactors with a catalyst and operating conditions that are selected to optimize the complex relationship among conversion, selectivity and energy consumption. The overall selectivity of isobutane to isobutylene via the CATOFIN process is greater than 90 mol% and the selectivity of propane to propylene is greater than 86 mol%. On-stream efficiencies of 98+%, excluding turnarounds of two to three weeks every three years for catalyst change, are routinely achieved.

The following information focuses on the dehydrogenation of propane to propylene.

## Advantages

Process Features	Process Benefits
High per pass conversion (48-53%) and high catalyst selectivity	Lower investment and operating costs
Single train capability up to 900,000 MTA of isobutylene or 850,000 MTA of propylene	Economy of scale
No hydrogen recirculation or dilution steam	Lower investment and operating costs
Fixed bed reactors	Reliable and robust operation with high on-stream factor
No catalyst losses	Environmentally sound design

## Performance Characteristics

(Propane Dehydrogenation)

Typical Feedstocks	Product
	<i>mol %</i>
Propane	95 min
Ethane	2.5 max
Butane +	2.5 max
Sulfur	10 wt ppm max
	Propylene
	99.5 mol% min
	Propane
	0.5 mol% max
	Ethylene + Ethane
	100 mol ppm max
	MAPD
	10 mol ppm max
	Carbon Oxides
	5 mol ppm max

## Process Flow Diagram

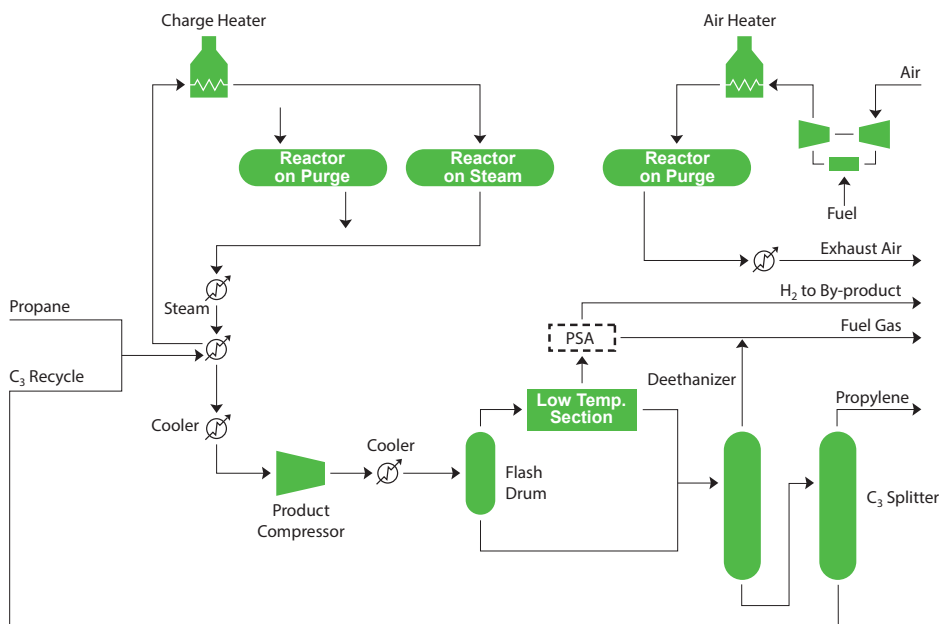

The diagram shown is for the production of propylene. For isobutylene production, the deethanizer and C<sub>3</sub> splitter are replaced by a depropanizer. A deoiler is also included to reject a small amount of C<sub>4</sub>s

and heavier material. For amylenes production, an extractive distillation system with a quench oil tower is used instead of the deoiler/splitter combination.

## Process Description

CATOFIN dehydrogenation is a continuous process with cyclic reactor operation in which multiple reactors go through a controlled sequence of reaction and reheat/regeneration. During the hydrocarbon processing step, fresh feed and recycle feed (from an MTBE synthesis unit or isobutane dehydrogenation or C3 splitter bottoms for propane dehydrogenation) are vaporized by exchange with various process streams and then raised to reaction temperature in the charge heater. The reactor effluent is routed through a high pressure steam generator, feed-effluent exchanger, and trim cooler to the compressor.

The compressor discharge is cooled, dried and routed to the low temperature recovery section to reject light ends. The low temperature section offgas, which is a

hydrogen-rich gas, can be sent to a Pressure Swing Adsorption (PSA) unit to purify the hydrogen. Recovered liquids from the low temperature recovery section, along with the effluent flash drum liquid, are fed to distillation facilities and/or an MTBE synthesis unit for product recovery.

The reactor temperature drops during the reaction step due to the endothermic reactions. Ancillary equipment is required for the reheat/regeneration steps, which are necessary to prepare the off-line reactors for their next reaction phase. During the reheat step, any carbon deposited on the catalyst is also burned off. The entire reactor sequence is computer controlled and requires no operator input for the cyclic operation.

## Process Chemistry

### Propane Dehydrogenation

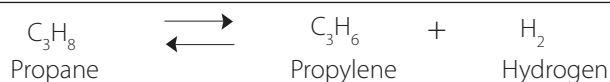

[www.CBI.com](http://www.CBI.com)

Only employees, agents, or representatives authorized under and pursuant to written agreement with CB&I are authorized to distribute this brochure to an actual or potential client of CB&I. ©Copyright 2014 by Chicago Bridge & Iron Company. All rights reserved.